

The Best Partner of
Energy, Water and Environment

MIURA

Ballast water
management system

HK

The Best Partner of
Energy, Water and Environment

MIURA

MIURA CO.,LTD.

Ship Machinery Dept.

7 Horie, Matsuyama, Ehime, 799-2696
TEL (+81) 899 79 7060 FAX (+81) 899 79 7082

ISO 9001 **ISO 14001**

Quality assurance system for boiler
and water treatment systems and
on-line maintenance service

Our head office and Hojo factory are
sites with a registered environmental
management system.

CAUTION In order to use the product safely, be cautious of safety and always read the "Operation Manual" before use.

© Cautions regarding exports: If the products in this catalog are included in the products subject to export restrictions as defined by the rules of the "Foreign Exchange and Foreign Trade Act," then export permission from the Japanese government is necessary when exporting the products outside of Japan.
If the products are to be exported, please make an inquiry to our sales staff.

Products may be changed without notice for improvement. The details shown in this catalog are the specifications for Japan. Please contact your nearest distributor or sales office with any inquiries regarding this catalog.

D500-009-6200-0 (09-620) The unauthorized reproduction of this catalog is strictly forbidden.
Updated in July 2022 011HA

We want to protect this wonderful natural world and pass it on to the next generation.

At MIURA, we will cherish those wishes and use the whole strength of the company to work towards our mission of “Helping customers all over the world in energy conservation and environmental preservation.” One major support for those efforts is the ballast water management system (BWMS), which contributes to the preservation of the marine environment around the world. Our Ship Machinery Department has over fifty years of proven results and experience and is playing a key role as we utilize our technology and the trust in MIURA and put all our efforts into the achievement of our aims.

MIURA acquired USCG type approval

In October 2019, MIURA acquired USCG (United States Coast Guard) type approval, for which preparations had long been underway, and became the first manufacturer in Japan to obtain such approval for the filtration method with UV treatment. Additionally, we acquired the type approval under the BWMS Code (revised G8) in February 2020. Looking to the future, we will continue to work to conduct a range of thorough checks in order to allow us to respond to the demands of our customers from a global standpoint, and offer safer products that provide greater peace of mind.

Environmentally friendly system with a uniquely developed filter and UV reactor combination

The greatest feature of the Miura BWMS is its structure, which uses a uniquely developed filter to capture microorganism of 50 μm or larger from the ballast water and then uses a UV reactor to irradiate the organisms with ultraviolet (UV) light to sterilize them. It is an environmentally friendly system with no impact on the organisms where the treated ballast water is discharged, because no active substances (chemicals) are used. It can continue to exhibit its performance in each of the different water qualities of sea water, brackish water and fresh water.

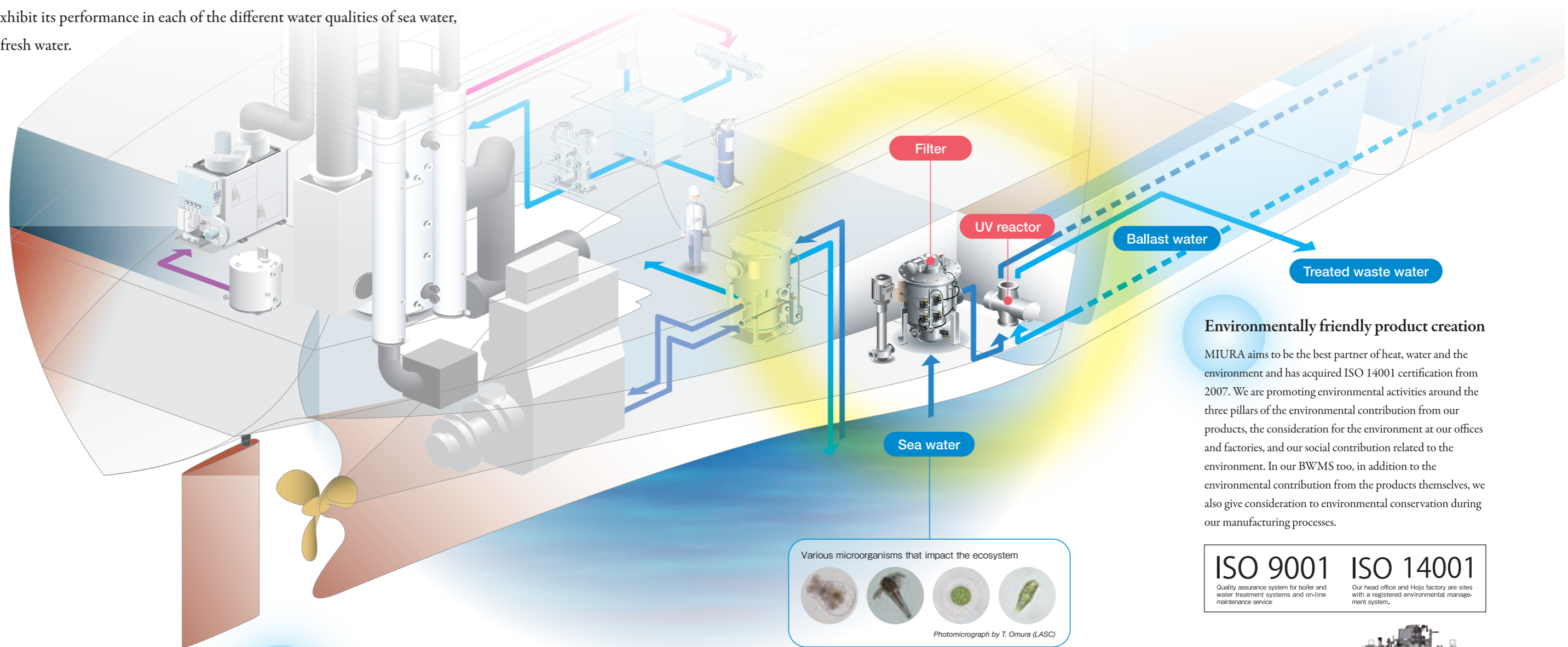

Environmentally friendly product creation

MIURA aims to be the best partner of heat, water and the environment and has acquired ISO 14001 certification from 2007. We are promoting environmental activities around the three pillars of the environmental contribution from our products, the consideration for the environment at our offices and factories, and our social contribution related to the environment. In our BWMS too, in addition to the environmental contribution from the products themselves, we also give consideration to environmental conservation during our manufacturing processes.

ISO 9001 Quality assurance system for boiler and water treatment systems and on-line maintenance service.
ISO 14001 Our head office and Hojo factory are sites with a registered environmental management system.

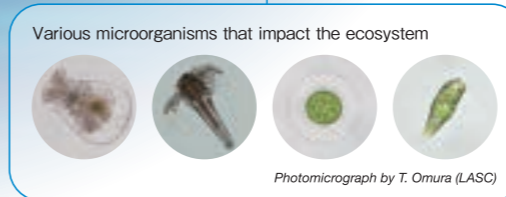

The obligation to install a ballast water management system

Ballast Water Management Convention came into force on September 8, 2017. This means that the installation of a "ballast water management system" is required for all newly constructed vessels that are completed from September 2017 onwards. Furthermore, all vessels currently in service are required to complete the installation before the renewal of their IOPP certificate, which is between September 2017 and September 2024. MIURA has sold BWMS since 2014 and has built up a proven record of their installation on newly constructed vessels and their retrofitting on vessels already in service.

Ballast water management systems to maintain the marine ecosystem

Miura BWMS is a clean type of system that combine a filter and sterilization using UV light. One feature of the method of sterilization using UV light is that no active substances are used during the treatment, so there is no impact on the organisms where the treated ballast water is discharged. We developed a filter for the management system that can reliably capture organism of 50 μm or larger and added a multi-stage cleaning function with high maintainability. The medium pressure UV pipe used in the UV sterilization was newly developed to save electricity and extend the service life and the optimal sterilization performance was achieved by using the illumination intensity and the flow rate to calculate and control the amount of irradiation.

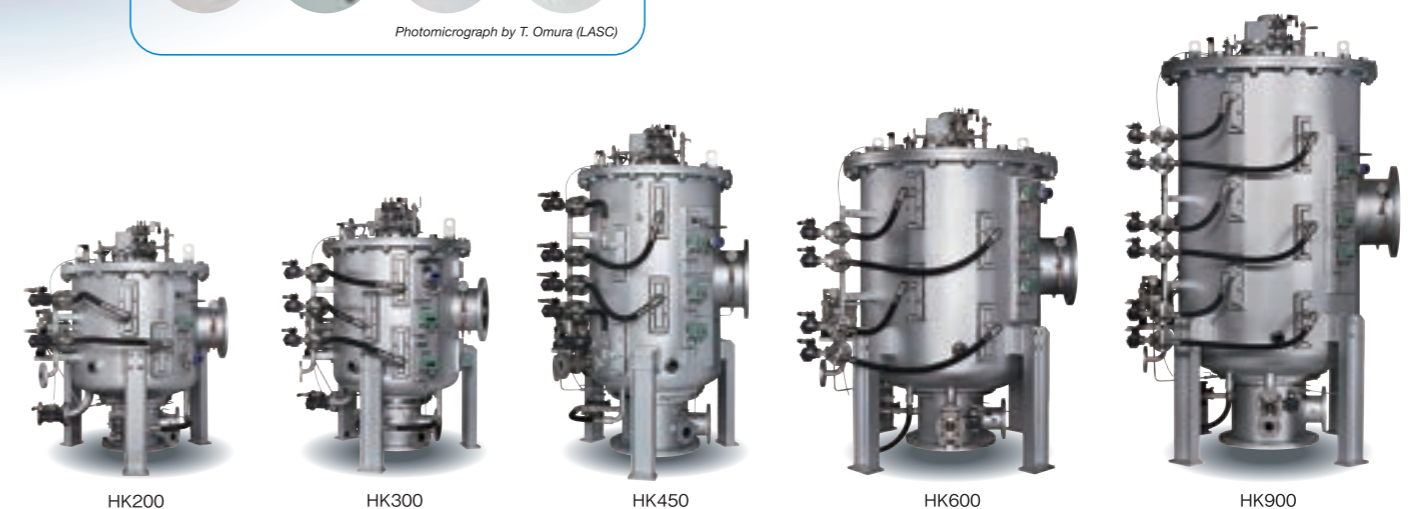

HK200

HK300

HK450

HK600

HK900

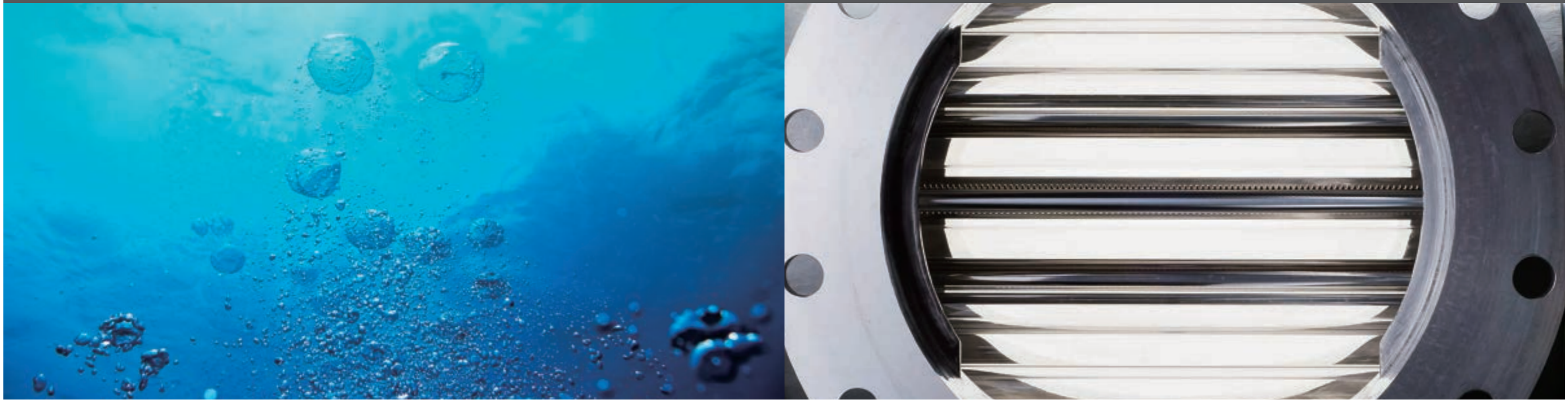

An original cleaning system to maintain the capture performance of the filter

MIURA has developed a filter with an innovative structure that makes filter cleaning possible at the same time as the capture of the organisms in the ballast water. With MIURA's unique multi-stage cleaning function, the maintainability and performance are supported and the capturing function of the filter is maintained. The filter is always maintained in a clean state, so it does not require the time and effort of the crew of the vessel and the primary duties in cargo handling can be performed smoothly.

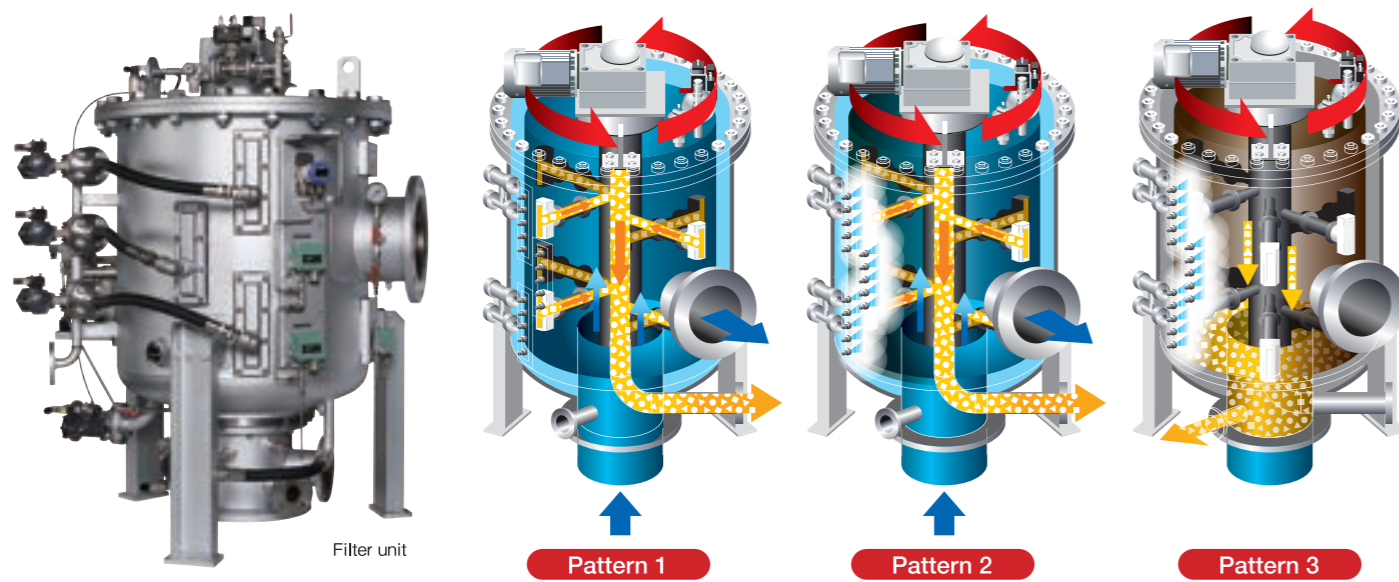

The three MIURA original cleaning patterns preserving the filter performance

In order to reduce the clogging of the filter, a function is included that can clean the filter element in multiple stages. With these three cleaning patterns, high pressure jet cleaning is performed from the outside of the filter element to keep the filter clean at all times and preserve the filter performance.

Reliable sterilization of organisms with a uniquely developed UV irradiation method

MIURA started the installation of the independently developed BWMS from 2014. As we have accumulated proven results in the installation of the system, we have also received favorable evaluations of the sterilization performance for S-sized and smaller organisms and for fungi. We are implementing repeated improvements to reduce power consumption and extend the service life and are aiming for further quality improvements. A cleaning function has been included inside the UV reactor to reduce the maintenance work that the crew of the vessel must perform.



Proportional control operation to realize reduced electricity consumption and longer service life

The short service life of UV lamp was previously the disadvantage of UV irradiation, but we have improved this with a method of operation that uses proportional control. A UV sensor monitors the UV illumination intensity and the amount of UV irradiation is controlled. This saves electricity and extends the service life.

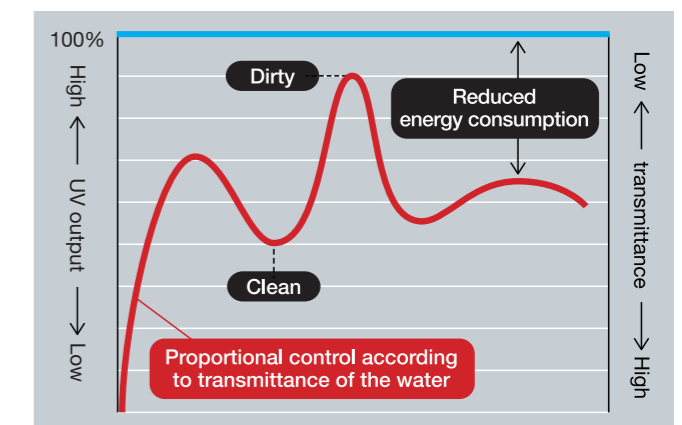

The touch screen type control panel easily operated from the ship's office

Day to day operation can be easily performed with remote control from a touch screen placed in the ship's office. The status of the system can be checked on the display on the control panel and if an alarm for "Filter differential pressure error" ever occurs, it is also possible to perform cleaning with just the press of one button. Furthermore, in order for customers to operate the system safely and with a feeling of reassurance, the equipment status that is displayed on the screen is categorized into the two levels of "Notifications" and "Alarms."



- ① Selecting "Ballast" or "Deballast"
- ② Checking the status
- ③ Touching "Confirmation"
- ④ Touching "Filter Wash" starts the cleaning of the filter element.



Control panels in engine room



Control panels in ship's office
(The remote control panel is optional.)

Manufacturer maintenance provided globally

In-house developed products, support from maintenance to parts supplies

The main parts were developed in-house at MIURA, so we provide support for everything from consumable parts to large-scale and functional components. We support the smooth operation of marine equipment with maintenance, preservation and management assistance that meets the needs of the customers.

Single engineer for all maintenance work

MIURA engineers have the technical ability to be able to cover all the maintenance work related to marine equipment on their own, including electrical, mechanical and water management work. As an individual engineer performs the maintenance reliably, this makes rapid support possible and also contributes to a reduction in maintenance costs.

MIURA's network across the world

In addition to our bases in Japan, we also have engineers at our bases in Singapore, the Netherlands, Taiwan, China and America. We have prepared a system to respond to customer requirements rapidly at any location around the world. This ability to provide the best possible support in both providing parts supplies and engineering services is a distinctive characteristic of MIURA.



Maintenance can be performed at any port around the world



Maintaining quality in line with the international standards to enhance safety



MIURA acquired USCG type approval in October 2019, and the type approval under the BWMS Code (revised G8) in February 2020. To further improve the product quality, a sea water test site in Hiroshima Prefecture and a fresh water test site in Ehime Prefecture are continuously in operation. Running tests are performed repeatedly. We are working actively to meet strict international standards while offering greater safety and security to customers, and endeavoring to protect marine environments the world over.



Fresh water test site
(Ehime Prefecture)



Sea water test site
(Hiroshima Prefecture)

A compact design that can be easily installed both on newly constructed vessels and in retrofitting

One major feature of the BWMS HK is their compact design. The equipment can be used for a wide range of applications, including both newly constructed vessels and retrofitting. The filter performance has been improved even further and we offer the high functionality and quality that are characteristic of MIURA.

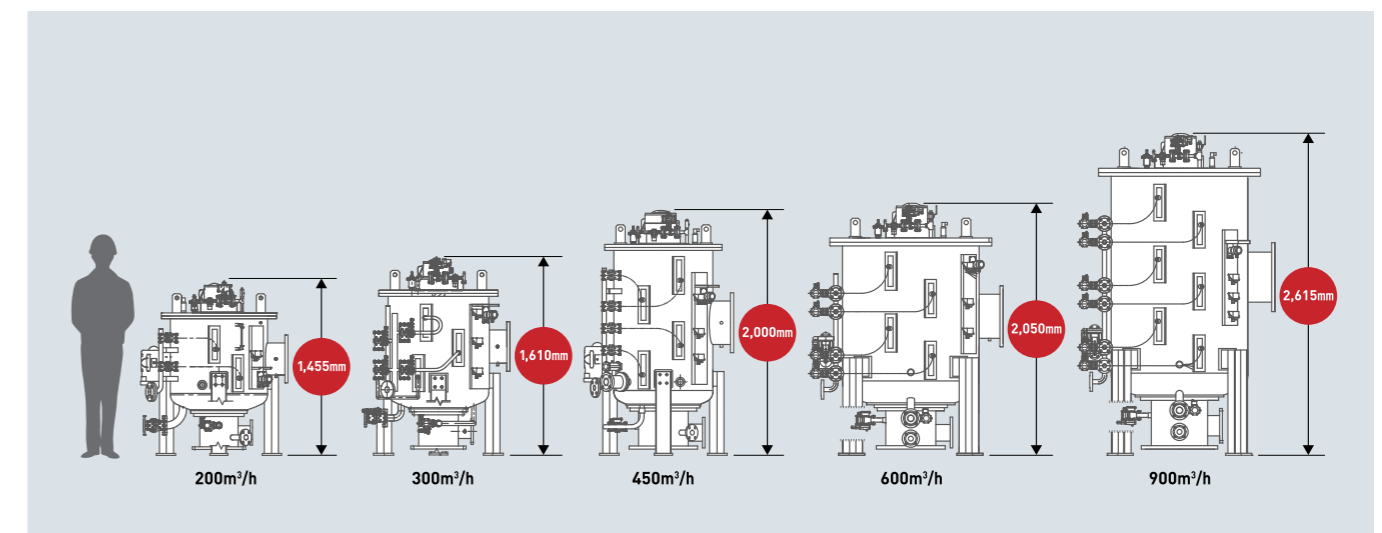

Example filter and UV reactor configurations

Select the capacity of the filter and UV reactor according to the ballasting and deballasting capacity.

* The following figures are typical examples of BWMS Code, HK-C, and HK-R.

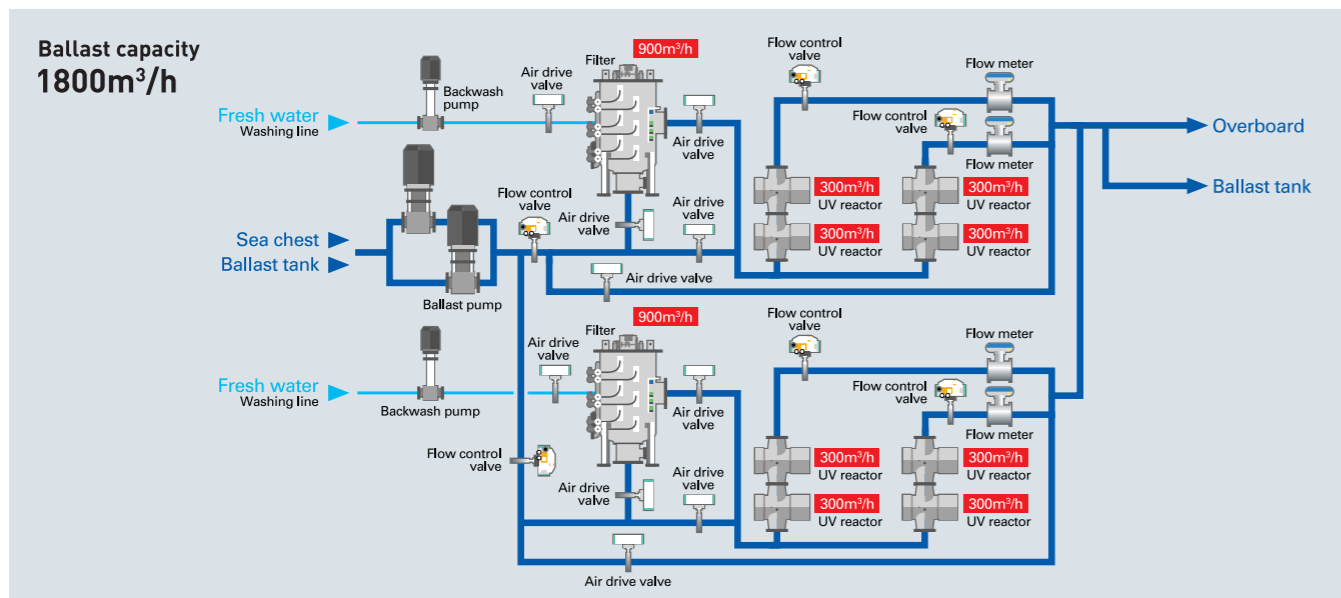
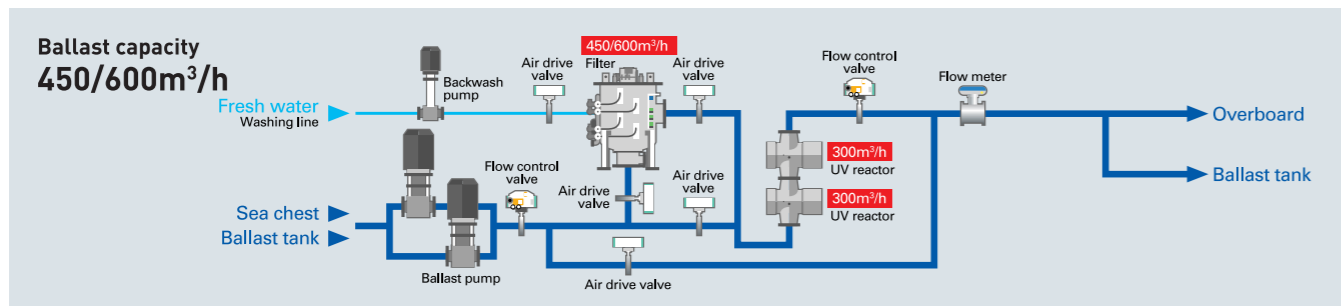
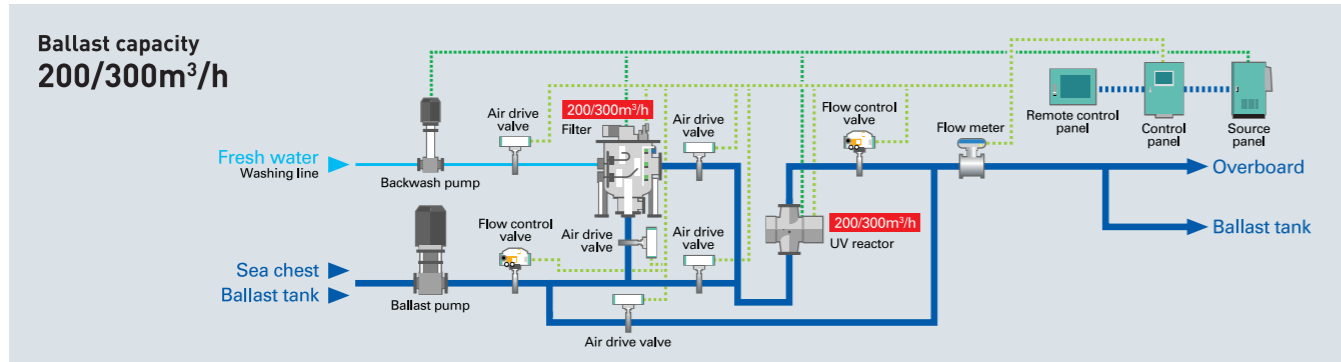

Filter	UV reactor	Capacity [IMO]		Capacity [USCG: Type C]		Capacity [USCG: Type R]	
		Ballast	Deballast	Ballast	Deballast	Ballast	Deballast
200F	06U	—	200	—	—	200	200
	10U	—	200	200	200	—	—
	08U	—	300	160	160	300	300
300F	12U	—	300	300	300	—	—
	06U × 2	06U + 06U	400	400	—	—	—
450F	08U × 2	08U + 08U	450	600	320	320	450
	10U × 2	10U + 10U	450	600	400	400	—
	12U × 2	12U + 12U	450	600	450	600	—
	08U × 2	08U + 08U	600	600	320	320	600
600F	12U × 2	12U + 12U	600	600	600	600	—
	08U × 2 + 08U	—	900	900	480	480	900
900F	12U × 2 + 12U	—	900	900	900	900	—
	08U × 2 + 08U × 2	—	900	1200	640	640	900
	12U × 2 + 12U × 2	—	900	1200	900	1200	—

* The above equipment configurations are typical examples. Contact a MIURA sales office for information on other configurations.

Basic specifications and external views

Filter unit

No.	Description	Size	Qty
N-1	Ballast water inlet	JIS 10K-300A	1
N-2	Ballast water outlet	JIS 10K-250A	1
N-3	Back wash water outlet	JIS 10K-100A	1
N-4	High pressure wash water inlet	JIS 20K-40A	1
N-5	High pressure wash water outlet	JIS 10K-40A	1
N-6	Purge air inlet	JIS 10K-15A	1
N-7	Filter wash water outlet	JIS 10K-40A	1
N-8	Air vent	Rc3/8	1

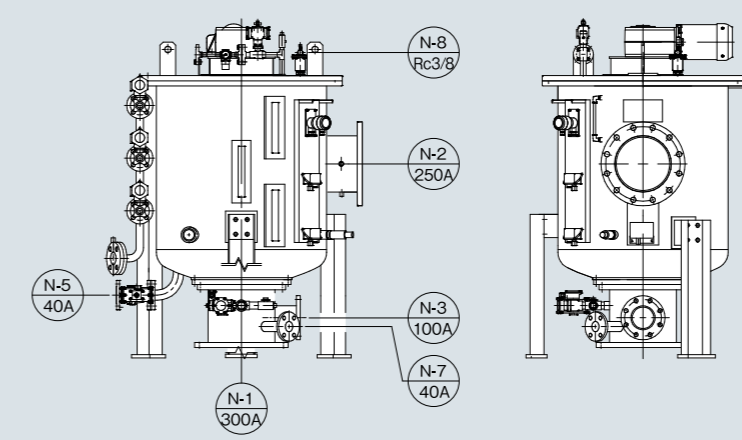
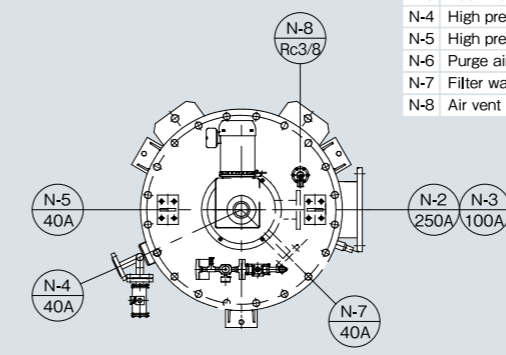

UV reactor

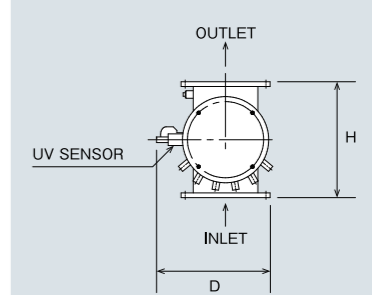
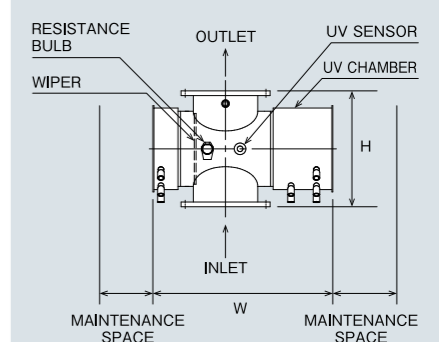

Control panel

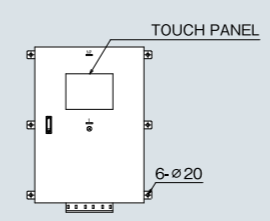

Source panel

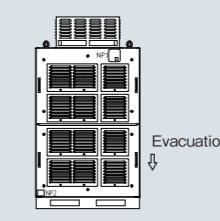

Remote control panel (option)

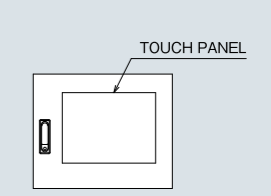

Equipment name	Standard flow rate [m³/h]	Dimensions (H × W × D) [m] *	Diameter (in/out) [A]	Weight [Kg]
Filter 200F	200	1445 × 1200 × 1095	300 / 250	800
Filter 300F	300	1610 × 1195 × 1095	300 / 250	900
Filter 450F	450	2000 × 1200 × 1075	400 / 350	1300
Filter 600F	600	2050 × 1485 × 1435	400 / 350	1700
Filter 900F	900	2615 × 1510 × 1435	450 / 400	2000
UV reactor	200/300	640 × 990 × 625	350 / 350	205
Control panel		1060 × 800 × 300		90
Source panel		1660 × 800 × 300		150
		1630 × 910 × 740		460
Remote monitoring panel		1920 × 910 × 740		560
		370 × 450 × 170		15
Power supply voltage		Source panel AC440V 60Hz 3ø, Control panel AC110V~220V 60Hz 1ø		
Design pressure		0.7 MPa		

* Space for maintenance is not included.

Previous installation results

We provide the optimal proposals for the customers developed over our previous results and experience in various installations.

Bulk carriers



Vessel type	28,000 DWT	Classification	NK
Country of construction	Japan	Installation place	E/R
Installation situation	Retrofit	Model	HK450 × 1
Installation location	Japan		



Vessel type	38,000 DWT	Classification	NK
Country of construction	Japan	Installation place	E/R
Installation situation	Retrofit	Model	HK600 × 2
Installation location	China		

Chemical vessels



Vessel type	12,000 DWT	Classification	NK
Country of construction	Japan	Installation place	Pump room
Installation situation	Retrofit	Model	HK300 × 1
Installation location	UAE		



Vessel type	8,700 DWT	Classification	NK
Country of construction	Japan	Installation place	Pump room
Installation situation	Newly constructed vessel	Model	HK300 × 1
Installation location	Japan		

Car carrier ships



Vessel type	6,000 UNITS	Classification	NK
Country of construction	Japan	Installation place	E/R
Installation situation	Retrofit	Model	HK300 × 1
Installation location	China		



Vessel type	3,900 UNITS	Classification	NK
Country of construction	Japan	Installation place	E/R
Installation situation	Retrofit	Model	HK300 × 1
Installation location	China		

General cargo ships



Vessel type	12,000 DWT	Classification	NK
Country of construction	Japan	Installation place	E/R
Installation situation	Retrofit	Model	HK200 × 1
Installation location	China		



Vessel type	38,000 DWT	Classification	NK
Country of construction	Japan	Installation place	E/R
Installation situation	Newly constructed vessel	Model	HK600 × 2
Installation location	Japan		

Previous installation results

Container ships



Vessel type	6,350 TEU	Classification	NK
Country of construction	Japan	Installation place	E/R
Installation situation	Retrofit	Model	HK600 × 1
Installation location	China		



Vessel type	5,888 TEU	Classification	NK
Country of construction	Japan	Installation place	E/R
Installation situation	Retrofit	Model	HK600 × 1
Installation location	China		

Tankers

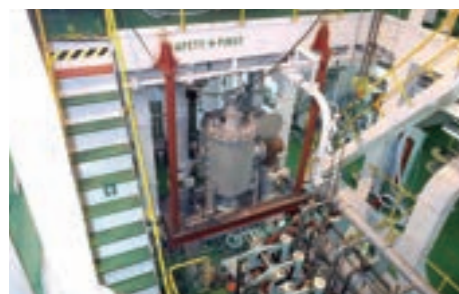

Vessel type	5,000 m³ LPG	Classification	NK
Country of construction	Japan	Installation place	E/R
Installation situation	Retrofit	Model	HK300 × 1
Installation location	Turkey		



Vessel type	7,200 m³ LPG	Classification	NK
Country of construction	Japan	Installation place	E/R
Installation situation	Retrofit	Model	HK300 × 1
Installation location	Curaçao		

We offer the optimal solutions for retrofitting. MIURA supervisors live up to the trust of the customers.

In the installation of BWMS, for retrofitting in particular, a wide variety of situations is assumed and detailed experience is necessary. MIURA has been developing ballast water management technology for many years and acts as a link between the vessel owner and the dock with a support system that has been prepared to realize safer and more flexible retrofitting. We use the technical ability we have built up in ship repair work and live up to the trust placed in us by customers with retrofits that fit with the dock schedule and also take economic efficiency into consideration.



The reasons why MIURA retrofits are selected around the world

- 1 **Installation is possible around the world.**
MIURA engineers go wherever necessary in the world to perform all the work from the 3D measurement on the vessel that is necessary at the design stage up to the actual installation work.
- 2 **We have expanded our support system with the improvement of our bases in China.**
In China, which could be said to be a global focal point for repair docks, MIURA has established facilities in Shanghai, Nantong, and Zhoushan, where it works in collaboration with local engineers to effect smooth installation work.
- 3 **Highly experienced supervisors provide full support for the installation work.**
Experienced supervisors from MIURA provide support for installation work. The supervisors cooperate with the foremen and docks to achieve installation work that delivers satisfactory system performance.



1 Planning

We perform detailed inspections and 3D scans, offering the perfect proposals for installation plans.

1 Preliminary investigations before visiting the vessel

Consideration performed using the documentation related to the vessel

- Parts layout, pump performance curves, piping system diagrams, power investigation tables, etc.

2 Investigation onboard the vessel

We visit ships in any location in the world we receive a request from.

3 Drafting a ship visit survey report

- Carry-in route
- Piping system checks
- Interviews regarding the situation of ballast operation
- Installation space
- Power investigation tables
- HK capacity proposal



4 3D scan

We perform 3D scans for the basis of the design. Experienced engineers from MIURA check the vessel from top to bottom, focusing on the interior structure.

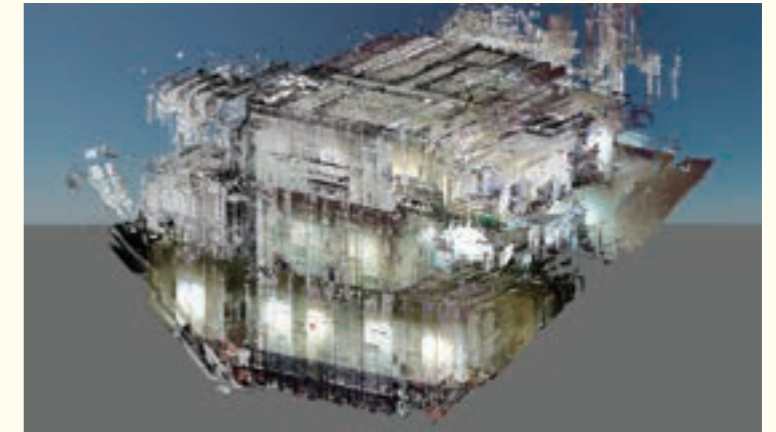

Example: Scan image from engine room on 37,000 DWT bulk carrier



Ship visit survey report

Actual examples of consideration

We propose remodeling plans that make use of our experience in order to make the installation the best possible.

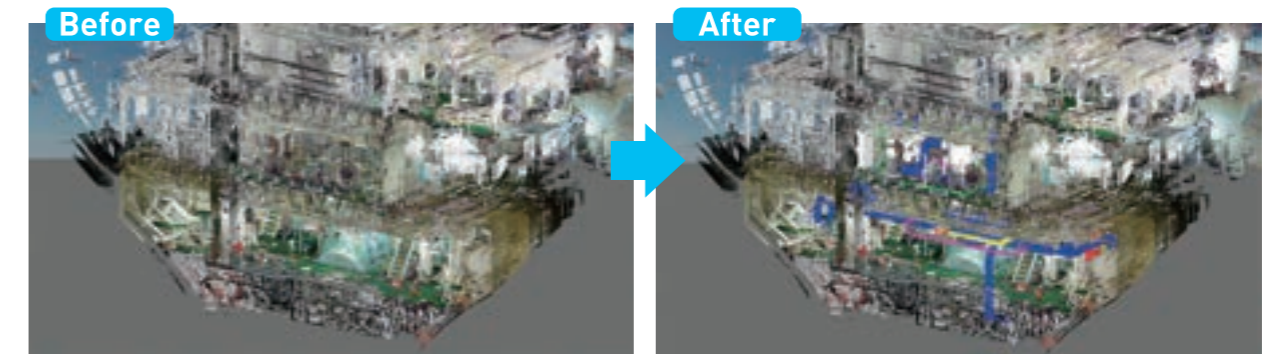

LOWER FLOOR, 3rd DECK main engine – Consideration of filter and reactor installation on the bow side.

The flow of retrofitting

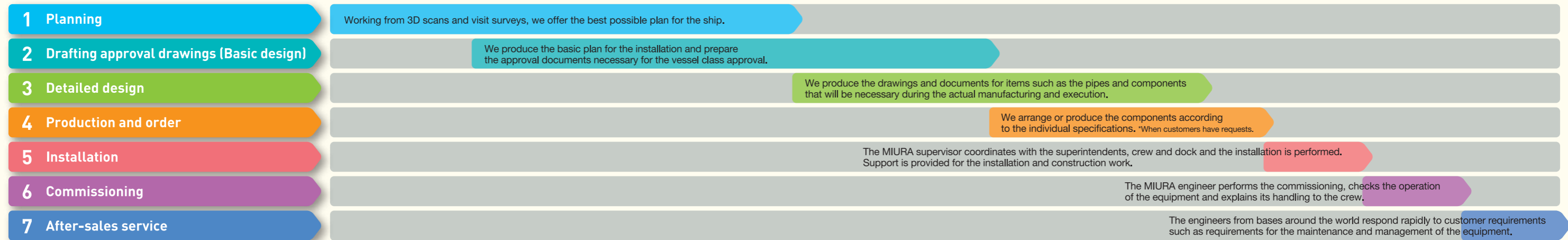



2 Approval

We produce the drawings to be submitted for the vessel class and other documents.

MIURA prepares the drawings and documents necessary for the approval. (Ballast water management plan (For D2), layout drawings, piping diagrams and ballast water loading/discharging operation flow charts, ballast water sampling facility diagrams, inspection procedure, etc.)

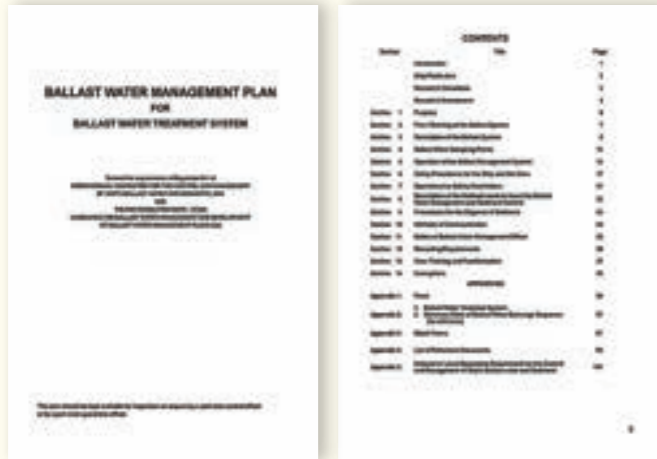

Ballast water management plan

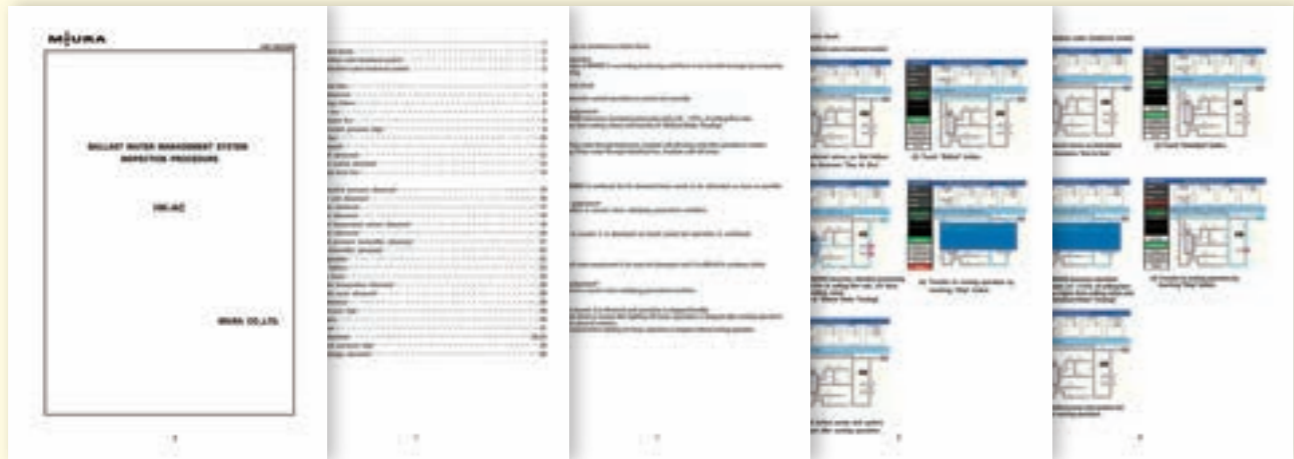

Onboard test method proposal

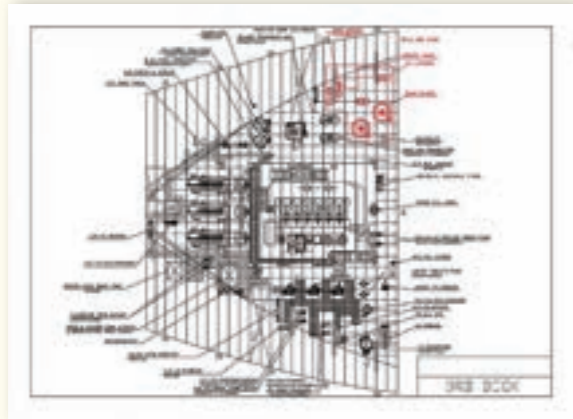

Parts layout

3 Detailed design

Working from the installation plan based on customer requests, we put together definite designs.

Detailed designs are created based on confirmed installation specifications. In the detailed design work, we create the drawings and documents required for actual manufacture and construction. We also draft piping production drawings, parts lists, piping layout drawings, etc.

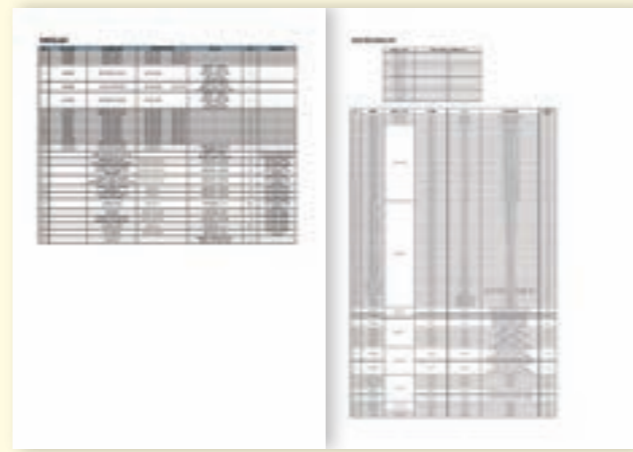

Parts list

Piping layout drawing

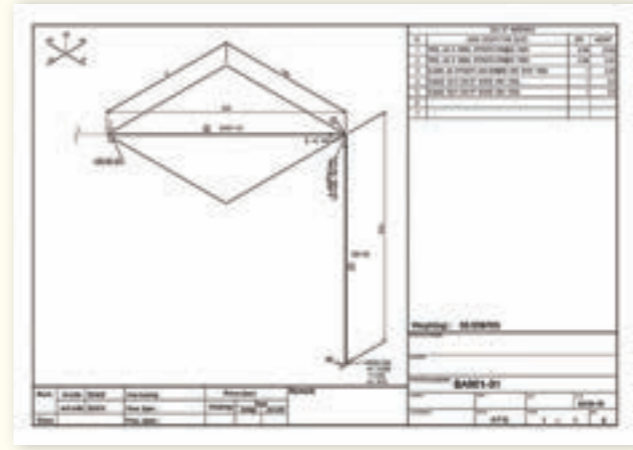

Piping production drawing

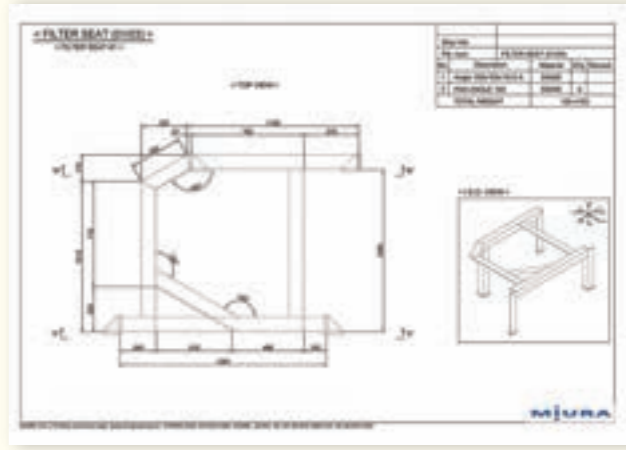

Frame production drawing

4 Production and order

We produce the parts in line with the design and in accordance with the various specifications.

We will provide parts based on the detailed design on request.
* As a general rule, equipment will be delivered at a predetermined domestic warehouse location and Free on Truck.



5 Installation

The MIURA supervisor provides support for the installation work.

Please rely on the MIURA supervisors for retrofitting installation work.

Experienced supervisors from MIURA cooperate with the foremen, sailors, shipbuilding companies, and repair docks to achieve installation work that delivers satisfactory system performance.

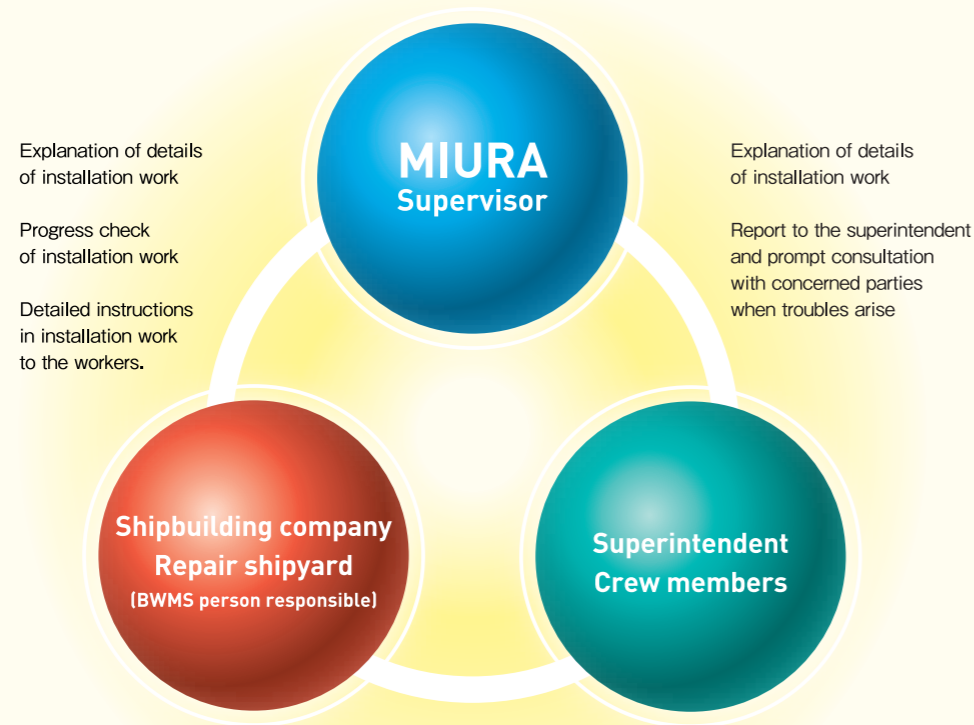

Using the installation work check sheet, we confirm that each installation is carried out according to plan.

Passing water through the pipes → Confirmation of no leakage → MIURA's SV filling our installation work check sheet → Results reported to the superintendent → Operation commissioning

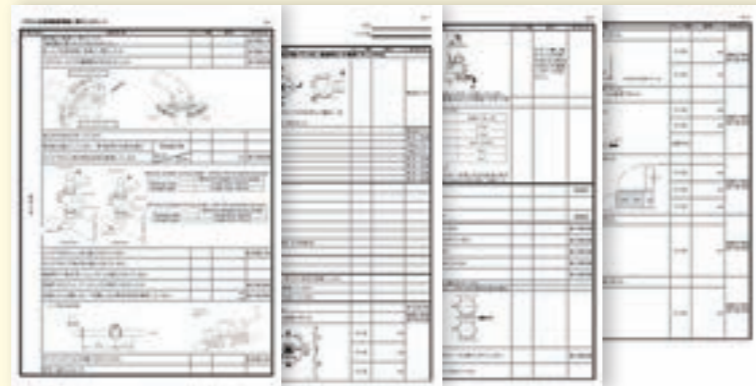

Installation work check sheet

6 Commissioning

MIURA's engineers carry out commissioning directly.

Commissioning is carried out by maker's engineers who possess deep knowledge about the equipment for a final check to ensure safe and secure sailing.

- Confirm installation of piping and electrical system
- Confirm operation and performance of each piece of equipment and the system as a whole
- Observe while undergoing inspection
- Confirm spare parts
- Provide instructions for operation

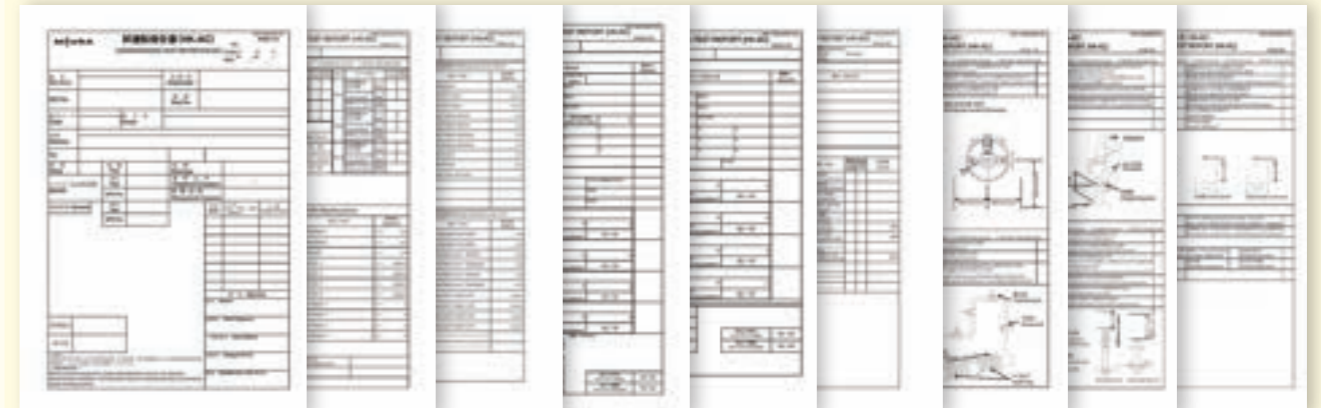

Commissioning report

After-sales service

MIURA also provides full after-sales service.

MIURA's inspection system "MZM" supports our customers' safe sailing.

We support the smooth operation of marine equipment with maintenance, preservation and management assistance that meets the needs of the customers. We accumulate the operation history data and utilize it for preventative maintenance and trend management.

MIURA's network across the world

We have opened bases in various locations around the world and have engineers stationed at those bases. We have prepared a system to respond rapidly to customer requirements. We provide the best possible support in providing parts supplies and engineering services.





Delivering reassuring and reliable MIURA technology to the oceans of the world.

In addition to Japan, MIURA also has bases in Shanghai, Zhoushan, Nantong, Taipei, Singapore, Amsterdam and Houston and we respond to the needs of customers in oceans worldwide.

HEAD OFFICE & FACTORY

Matsuyama Marine Business Headquarters
7 Horie, Matsuyama, Ehime, 799-2696, Japan

JAPAN SERVICE OFFICES

Tokyo Ship Machinery Tokyo Sales Section /Maintenance Section
TEL: (+81) 3 5793 1047 FAX: (+81) 3 5793 1045

Hiroshima Ship Machinery Shimanami Sales Section /Maintenance Section
TEL: (+81) 84 930 0740 FAX: (+81) 84 930 0741
Ship Machinery Hiroshima Maintenance Section
TEL: (+81) 82 850 3577 FAX: (+81) 82 850 3566

Imabari Ship Machinery Imabari Sales Section
TEL: (+81) 898 22 6283 FAX: (+81) 898 22 6277
Ship Machinery Imabari Maintenance Section
TEL: (+81) 898 22 6284 FAX: (+81) 898 22 6277

Fukuoka South Korea Marine Sales Section
Ship Machinery Kyushu Sales Section /Maintenance Section
TEL: (+81) 92 432 3277 FAX: (+81) 92 432 3278

OVERSEAS NETWORK

■ **MIURA INDUSTRIES (CHINA) CO., LTD. SHANGHAI BRANCH, SHIP MACHINERY DIV.**
Floor 2, Building 4, No.658 Jinzhong Rd., Changning Dist., Shanghai
TEL: (+86) 21 6447 9246 FAX: (+86) 21 6447 9502

■ **NANTONG BRANCH**
Room 1004-1005, South Century 34, Chongchuan Dist., Nantong, Jiangsu
TEL: (+86) 513 8118 7502

■ **ZHOUSHAN BRANCH**
Room 1402, Jinyue Building, No.620 Dingshen Road, Lincheng Street, Dinghai Dist. Zhoushan of Zhejiang Province
TEL: (+86) 580 2261 606 FAX: (+86) 580 2268 268

■ **MIURA CO., LTD. TAIPEI BRANCH**
10F-2, No.51, Songjiang Rd., Zhongshan Dist., Taipei 104094
TEL: (+886) 2 2732 1250 FAX: (+886) 2 2732 9030

■ **MIURA SINGAPORE CO PTE.LTD.**
No.3 Soon Lee Street #03-36-37-38, Pioneer Junction Singapore. 627606
TEL: (+65) 6465 1147 FAX: (+65) 6465 1148
mse-enquiry@miuraz.com

■ **MIURA NETHERLANDS B.V.**
Buitenveldertselaan 106, 1081AB Amsterdam
TEL: (+31) 20 661 6372 FAX: (+31) 20 661 6373
miuranetherlands@miuraz.com

■ **MIURA AMERICA CO., LTD. MARINE DIV.**
9252 Park South View, Suite 121, Houston, TX 77051
TEL: (+1) 470 279 2209
miuraz_marine@miuraz.co.jp

■ **MING YUNG MACHINERY, LTD.**
27 Shin Shing Street, Yan Cherng District, Kaohsiung
TEL: (+886) 7 521 6266 FAX: (+886) 7 521 9368

■ **YU-CHEN MARINE SERVICE & ENGINEERING CO., LTD.**
No.11 Hsin Fu Rd., Chien Cheng Dis., Kaohsiung 80672
TEL: (+886) 7 812 0376 FAX: (+886) 7 812 0361
e8120376@ms41.hinet.net

■ **SCANDINAVIAN BOILER SERVICE A/S**
Industrivej 12 9490 Pandrup
TEL: (+45) 7027 1000 FAX: (+45) 7027 1001

■ **TAKNAS MARINE ENGINEERING GMBH**
Fruchthof Oberhafenstr., 1 20097 Hamburg
TEL: (+49) 40 32 1305 FAX: (+49) 40 33 0608

■ **DONG YANG ENGINEERING**
#10-11, 2ka Myeong-ryun-dong, Dongrae-ku, Busan
TEL: (+82) 51 552 6503 FAX: (+82) 51 557 4830

■ **SEIN BESTECH**
302, 64, keumo-5gll, Dong-myeon, Yangsan, 626-821
TEL: (+82) 51 961 7771 FAX: (+82) 51 961 7772

■ **FUJI TRADING (MARINE) B.V.**
Kortenoord 2-8, 3087 AR Rotterdam
TEL: (+31) 10 429 8833 FAX: (+31) 10 429 5227

■ **SYORI GO TRADING INC.**
Room 402 Burke Building, Escolta cor. Burke Sts., Brgy. 291, Binondo, Manila City, 1006
TEL/FAX: (+02) 5310 1674
syorigo@ny-tokyo.com

■ **FUJI HORIGUCHI ENGINEERING PTE.LTD.**
24 Chia Ping Road, Singapore 619976
TEL: (+65) 6863 6368 FAX: (+65) 6863 8310

■ **JAPAN MARINE UNITED SINGAPORE PTE. LTD.**
16E Tuas Avenue 1 #02-63 JTC Space @ Tuas Singapore 639537
TEL: (+65) 6268 7360 FAX: (+65) 6268 5827
sales@jmus.com.sg

■ **SBS REPAIR (S) PTE LTD, Singapore**
094 Tagore Lane, Singapore 787587
TEL: (+65) 6767 0200 FAX: (+65) 6364 0400

■ **TAKNAS ENGINEERING PTE. LTD.**
102, Pandan Loop Singapore 12310
TEL: (+65) 6777 5856 FAX: (+65) 6779 6711